



ULT U100

GB Instructions for use

Warning

As the appliance contains a flammable refrigerant, it is essential to ensure that the refrigerant pipes are not damaged.

The quantity and type of the refrigerant used in your appliance is indicated on the rating plate.

Standard EN378 specifies that the room in which you install your appliance must have a volume of 1m³ per 8 g of hydrocarbon refrigerant used in the appliances. This is to avoid the formation of flammable gas/air mixtures in the room where the appliance is located in the event of a leak in the refrigerant circuit.

WARNING:

Keep ventilation openings in the appliance's cabinet or in the built-in structure clear of obstruction

WARNING:

Do not use other **mechanical devices** or other means to accelerate the defrosting process than those recommended by the manufacturer

WARNING:

Do not damage the refrigerant system

WARNING:

Do not use **electrical appliances** inside the refrigerated storage compartment, unless they are of a type recommended by the manufacturer

WARNING:

Do not expose the appliance to rain, and secure not splashing water when cleaning the floor

WARNING:

This appliance is not intended for use by persons (including children) with reduced physical, sensory or mental capabilities, or lack experience and knowledge, unless they have been given supervision or instructions concerning use of the appliance by a person responsible for their safety. Children should be supervised to ensure that they do not play with the appliance

WARNING:

If a not compatible USB pen drive is used it can cause a reset of the controller

WARNING:

Do not store explosives, such as aerosol cans with flammable propellants in the unit.

WARNING:

Danger risk of fire or explosion if flammable refrigerant are used. To be repaired only by trained personnel.

**WARNING:**

Sharp edges on cabinet, compressor compartment, evaporator, ventilation cover and on internal equipment can occur. Please be aware to avoid injury.

WARNING:

The condenser on the back of the appliance will in some cases have a hot surface. Please be aware to avoid injury.

- Always keep the keys in a separate place and out of reach of children
- Before servicing or cleaning the appliance, unplug the appliance from the mains or disconnect the electrical power supply
- If the supply cord is damaged, it must be replaced by the manufacturer, its service agent, or similarly qualified persons in order to avoid a hazard
- **Relevant for Australia:** Supply cord fitted with a plug complies with AS/NZS 3112.
- Please note that changes to the appliance construction will cancel all warranty and product liability
- This device is intended to be used exclusively for medical products.
- If the instructions is lost please contact your supplier of the appliance to have a new instruction for use.
- If service needed to this device, please be aware of only using service personnel with education in handling medical devices.



Contents

Warning	2
Get to know your freezer	4
Unpacking the appliance.	5
Before starting the appliance.....	6
Electrical connection.	7
Battery backup system at start-up	8
Installation and start-up	9
Maximum shelf load.....	10
Ventilation guards.	10
Interior fitting.....	11
Port hole	14
Reversible door	16
Controller. Operation and function.....	24
Defrosting, cleaning and maintenance .	27
Fault finding	29
Warranty, sparepart and service.....	30
Disposal.....	31

Get to know your freezer:

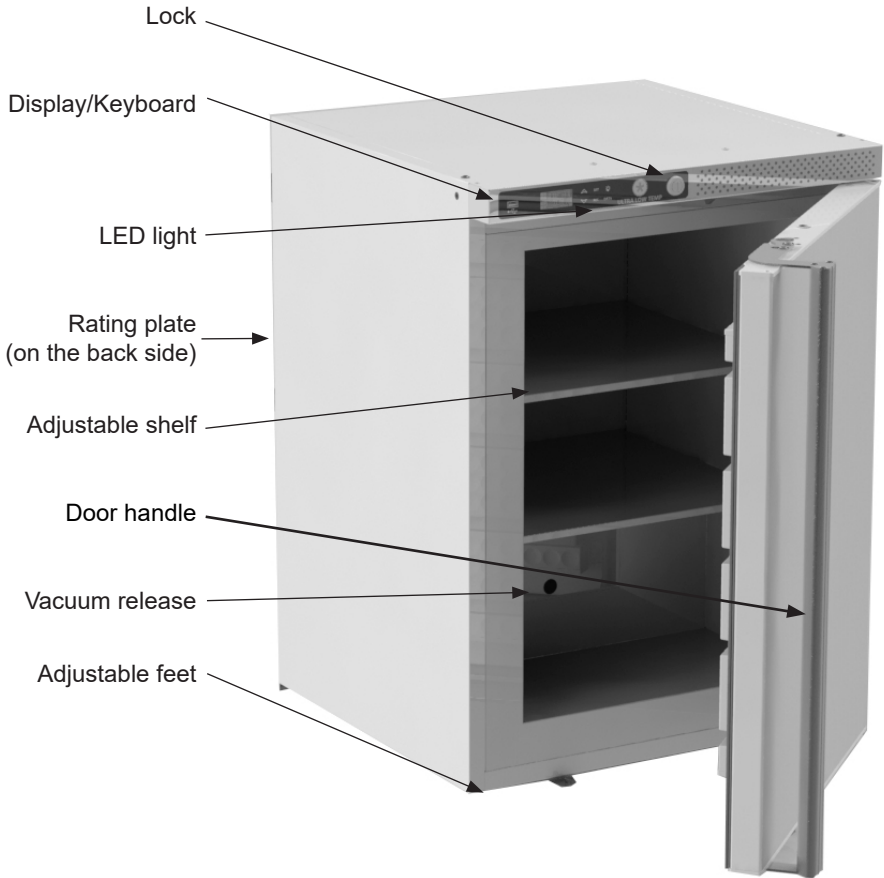

fig. 1

Unpacking the appliance

The appliance is delivered in a re-usable wooden box.



1. Reusable wooden package



2. Cut the strapex bands or see next page if sealed with plast clips

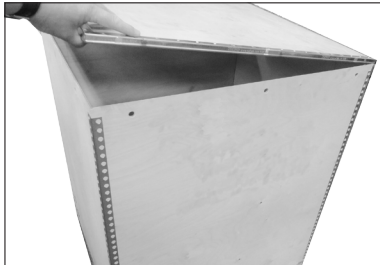

3. Remove top

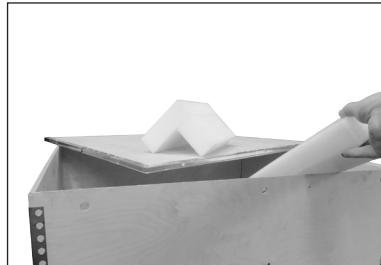

4. Remove top foam inlays



5. Remove box and lift down the appliance

Before starting the appliance

Before operating your new appliance, please read the following instructions carefully as they contain important information on safety, installation, operation and maintenance. Keep the instructions for future reference.

On receipt, check to ensure that the appliance has not been damaged during transport. Transport damage should be reported to the local distributor before the appliance is taken into use.

Clean the inside of the cabinet according to the cleaning instructions.

If during transport the appliance has been laid down, or if it has been stored in cold surroundings (colder than $+5^{\circ}\text{C}$), it must be allowed to stabilise in an upright position for at least an hour before being switched on.

Note: If the appliance is to be laid down, the door must face upwards and the appliance must be enclosed in the original packaging.

Electrical connection

Wiring and connections in power supply systems must be all applicable (local and national) electrical codes. Consult these codes lengths and sizes prior to cabinet installation.

This device complies with relevant EU directives including Low Voltage Directive 2014/35/EU and Electromagnetic Compatibility Directive 2014/30/EU

The socket should be freely accessible.

Connect the appliance only to 220/240 V / 50Hz alternating current via a correctly installed earthed socket.

The socket must be fused with a 10A or 13A fuse

If the appliance is to be operated in a non-European country, check on the rating plate whether the indicated voltage and current type correspond to the values of your mains supply.

Data regarding voltage and absorbed power / current are given on the rating plate.

The power cord may be replaced by a technician only.

The rating plate provides various technical information as well as type and serial number.

Room temperature

The climate class is stated on the name plate. This specifies the optimum room temperature.

The appliance operates best at room temperatures: +16°C to +25°C

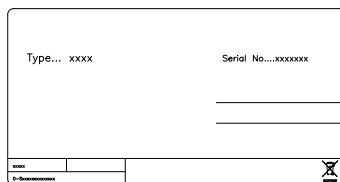

fig. 3

Battery backup system at start-up

This appliance is equipped with a battery back up system.

Please activate the battery backup before final placement (see fig. 2)



fig. 2

Use a pen or screwdriver to push the button through the above hole on the appliance backside. This will switch on the battery backup system.

Then please check the battery backup image  appears in the front display lower left corner.

This shows the battery backup is activated.

NOTE!

The battery backup system does not supply the cooling system with power.

When starting up the appliance for the first time it is necessary to switch on the battery backup system.

NOTE!

The battery for back up should be changed every third year to secure 48 hours of back up. Please put this change in the maintenance schedule for every third year.

Battery backup function

The battery backup system supplies the controller and keyboard with power at power failure. This makes it possible to supervise the temperatures in the unit during the power failure.

The battery backup system makes it possible to supervise the temperatures for 48 hours.

After a power failure and at the first start up the battery needs to be recharged. To regain the full capacity the battery will be reloading for 10 days

Installation and start-up

The appliance viewed from above

If the appliance is placed beside a wall, there must be sufficient room for its door to be opened wide enough to allow the shelf to be pulled out (fig. 4)

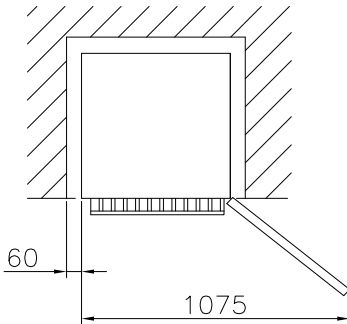

fig. 4

Ventilation

It is important that the appliance is well ventilated and that air can circulate freely above, below and around it. The figures (fig. 4-6) illustrate how the necessary air circulation around the appliance is ensured.

Setting up

It is important that the appliance is absolutely level. It can be levelled by screwing the adjustable feet of the appliance up or down.

Use a spirit level to check that the appliance is absolutely level sideways.

If the appliance is placed on a soft surface, e.g. floorboards or a carpet you must recheck whether the appliance is still level after a period of time as the underlying surface may yield under the weight of the appliance.

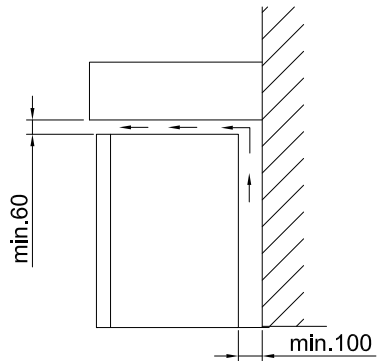

fig. 5

Side by side

In side-by-side arrangements there must be at least 60 mm between each unit on each side of the cabinets, to ensure the doors can be opened freely (See fig. 6)

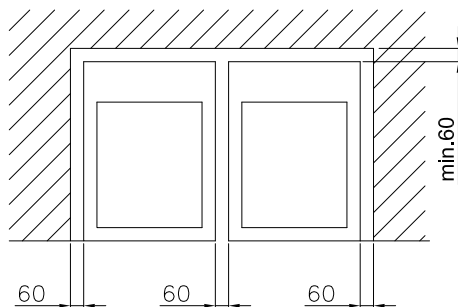

fig. 6

Ventilation guards

The two ventilation guards are mounted before moving the appliance to its final placement. The guards function is to secure an absolute minimum of ventilation, if the appliance is pushed too close up against a wall.

Remember our guideline is minimum 100 mm free space behind the appliance to ensure sufficient airflow.



1. Locate the left $\varnothing 15$ mm hole in the engine cover on the appliance back. Push a guard in the hole

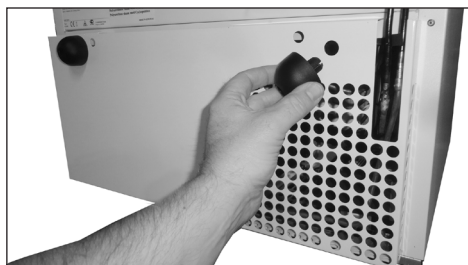

2. Then locate the identical hole in the right side of the engine cover and push the last guard into this hole

Maximum shelf load

The stainless steel shelves are designed to carry the weight of max. 15 kg each.



Interior fitting

Stainless steel shelf

The shelves are demountable and the height position is adjustable.

Demounting

The shelf is demountable without use of tools:



Lift up to release all hooks and pull the shelf to one side. Then tilt the shelf upwards in the free side and lift it out

Remounting in new height position

The shelf is remounted by following a few simple steps:

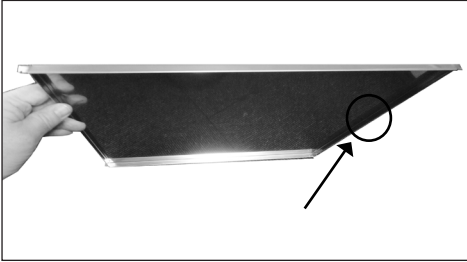

1. The shelf hooks are smallest in the rear edge.
Make sure the shelf direction is correct, by ensuring the small punched "half moon" is placed in the right side

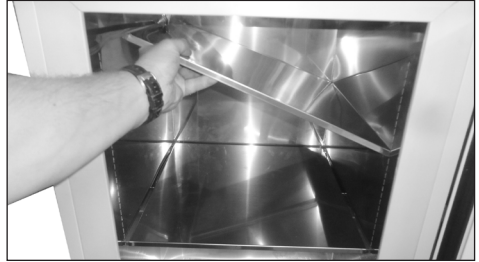

2. Place one side of the shelf hooks in the new height position



3. Gently press the hooks into the holes



4. Level the shelf and slide the hooks into the opposite holeside. Press down to ensure all hooks have fallen into place

Port hole

The freezer is equipped with an extra port hole. Ex. for use of an external sensor.

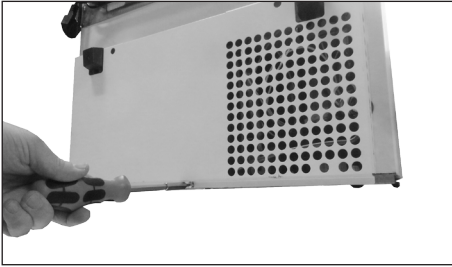

1. Remove 3 screws in the cover for the compressor compartment and remove the cover.

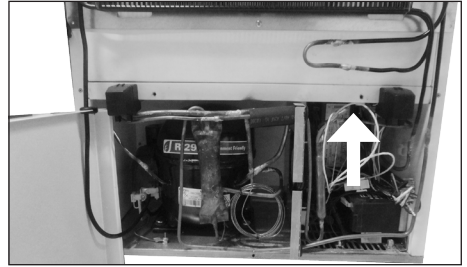

2. Place the cover at the side of the freezer. Still connected to the wire.
3. The port hole is placed at the right side.

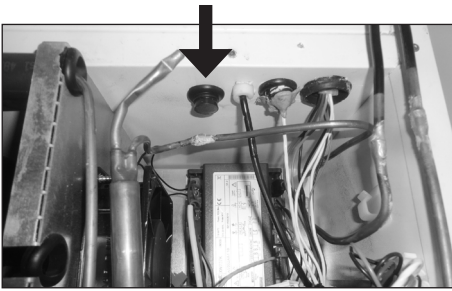

4. Inside the port hole is located in the top right side and is closed with a rubber plug.



5. Remove the rubber plug.



6. Inside the port hole is located in right in the top.



7. Remove the rubber plug.

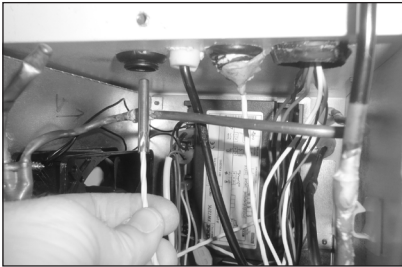

8. Put in the sensor and push it all way through the tube.

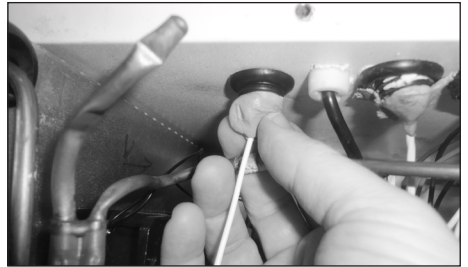

9. Closed the port hole by using putty

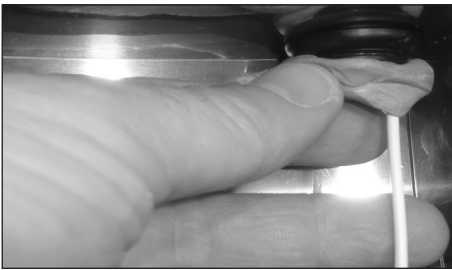

10. Close the inside hole by using putty

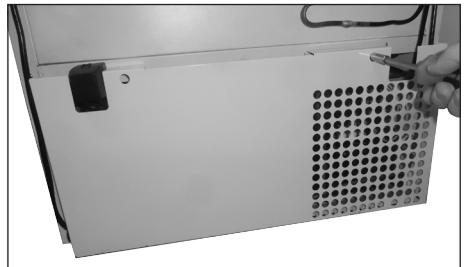

11. Fasten the cover with the 3 screws

Reversible door



1. For a hingeside change turn off main power and place the appliance on a table. Protect top from scratches.



2. Loosen and remove visible top screws (use 3 mm allen key + Torx 20 tool)



3. Open the door to gain access.



4. Remove three screws underneath the toppanel (use 3 mm allen key)



5. Remove lock pin (use 4 mm allen key)



6. Carefully pull out the toppanel...

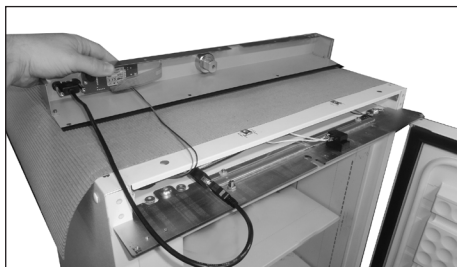

7. ...and place it upside down on the cabinet top

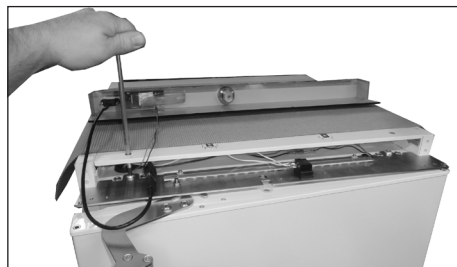

8. Loosen 2*M8 screws approx. 5 mm (use 5 mm allen key)



9. Loosen pivot nut (use 10 mm spanner)



10. Lift up the top bracket/pivot. Pull out the door and lift it off the bottom pivot



11. Loosen door top pivot (use 2,5 mm allen key if necessary)

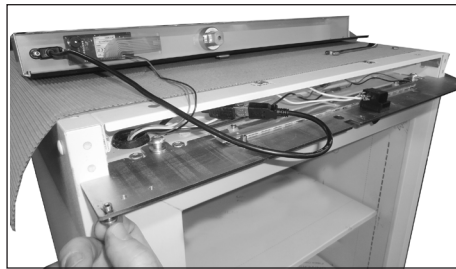

12. Remount pivot in the new hinge side

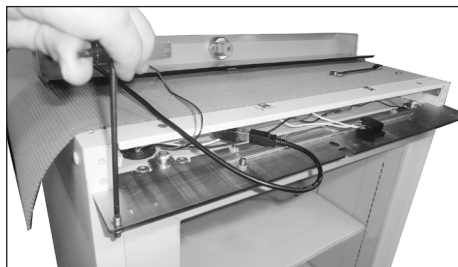

13. Tighten pivot (2,5 mm allen key)



14. Tighten pivot nut

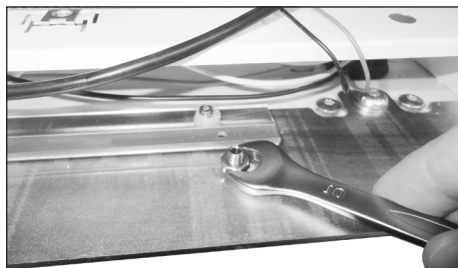

15. Demount fix nut and top handlelock pin

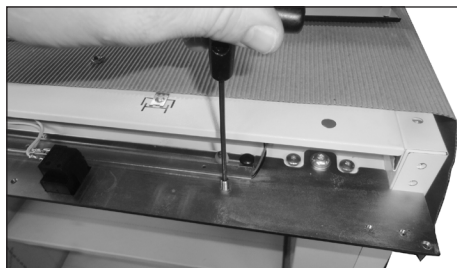

16. Remount the top handlelock pin in the opposite side. Tighten the fix nut again



17. Go to bottom and remove the door pivot nylon washer



18. Remove the two front feet

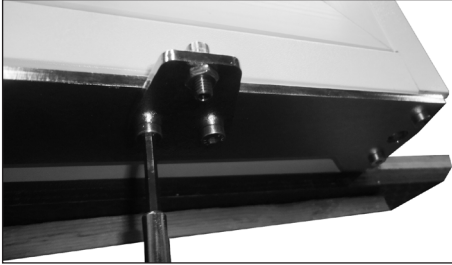

19. Remove bottom handlelock pin plate by loosening two screws (use 4 mm allen key)

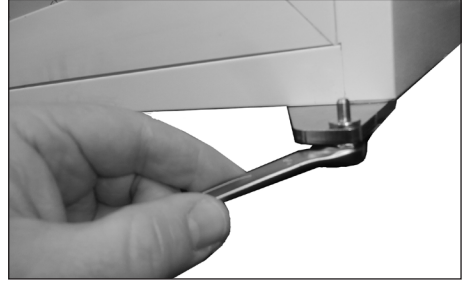

20. Loosen bottom pivot nut

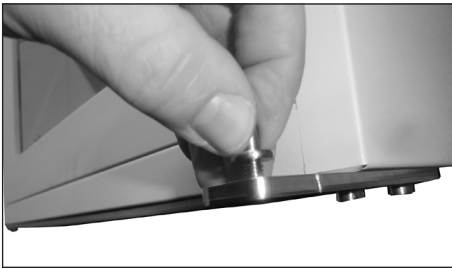

21. Loosen door bottom pivot

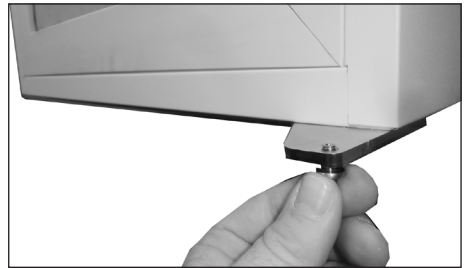

22. Remount door pivot for use in new hinge side



23. Tighten pivot



24. Remount and tighten pivot nut

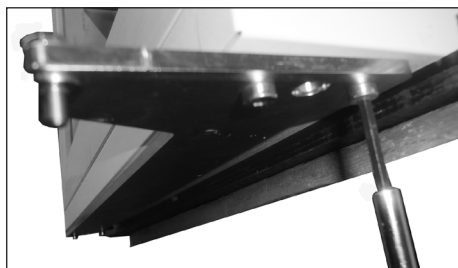

25. Loosen the bottom door bracket screws in one side (use 4 mm allen key)

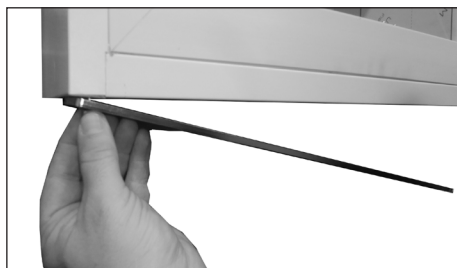

26. Loosen the screws in the opposite side and rotate the bottom door bracket

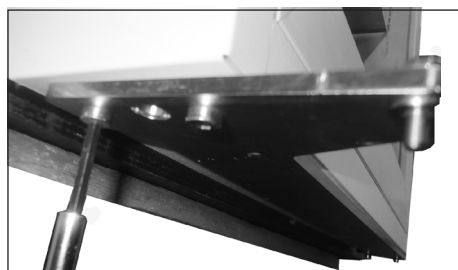

27. Then remount and tighten the screws in both sides



28. Re-position the door pivot nylon washer



29. Remount bottom handle lockpin plate in the opposite side by tightening the two screws again (use 4 mm allen key)



30. Remount and tighten the two front feet



31. Go to the current door bottom and de-mount two screws from the door closer (use Torx 20 tool)

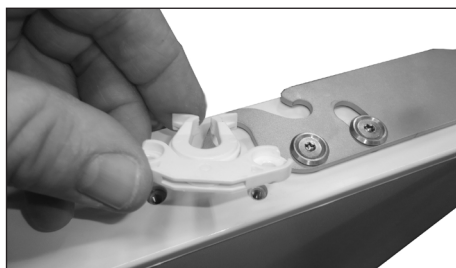

32. Remove the door closer and keep it ready for mounting in the "new" door bottom



33. Remount the two screws without the door closer



34. Rotate the door

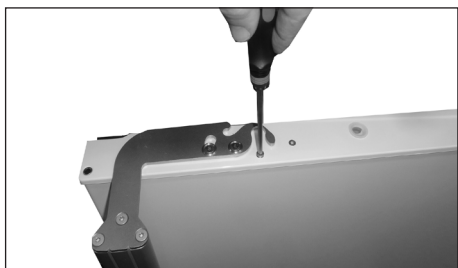

35. Unscrew the two doorcloser screws in this new door bottom end (use Torx 20 tool)

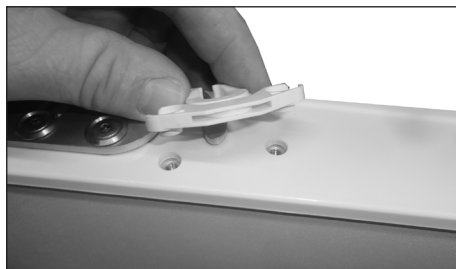

36. Place the doorcloser in the empty threadholes



37. Remount the two screws and the door-closer is fixed



38. Re-locate the door on the cabinet in the new hingeside



39. Tighten the two M8 screws in the top bracket



40. Carefully push the toppanel back into position



41. Remount the three screws upwards in the toppanel...



42....and remember the screw close to the top door pivot is mounted in hole nr.2 inwards, to ensure sufficient space between the screw and the door end-cap during mounting



43. Remount the lock pin



44. Remount the four topscrews



45. The door re-hinging operation is now complete

Controller. Operation and function

User interface





LEDS

Each LED function is described in the following table.

LED	MODE	Function
	ON	Compressor enabled
	Flashing	Anti-short cycle delay enabled
	ON	An alarm is occurring
	ON	Recording activated
	ON	Battery is fully charged
	Flashing	Battery is beeing charged
	Flashing	Charging problem or battery failure
°C/°F	ON	Measurement unit
°C/°F	Flashing	Programming phase

Buttons

SET	To display target set point; in programming mode it selects a parameter or confirm an operation.
	To enter fast access menu In programming mode it browses the parameter codes or increases the displayed value. (DOWN); n programming mode
	In programming mode it browses the parameter codes or decreases the displayed value. Push it for 3s to start a manual defrost
DATA	Export data from button
	To switch off the light in the door (only models with light in the door)
REC	Log activation and deactivation from button (Password protected)

How to see and modify the setpoint

How to: See the Set point

1. Push and immediately release the SET key: the display will show the Set point value.
2. Push and immediately release the SET key or wait for 60 sec to display the temperature in the unit

How to: Change the Set point

1. Push the SET key more than 2 sec to change the Set point value.
2. The value of the set point will be displayed and the “°C” LED will start blinking.
3. To change the Set value push the UP or DOWN arrows within 60 sec.
4. To save the new set point value, push the SET key again and wait for 3 sec.

NOTE: To exit without making any change to the set point, push the SET key or wait 60 sec.



Clock settings and RTC alarm reset RESET

1. Push the UP key once, to acces the menu.
2. The display shows H0, then push SET.
3. The parameters for setting time and date occurs. To set the parameter push SET, push the UP or DOWN button to change the parameter. Confirm by pushing SET.

The time and date parameters:

Hur: hour
0in: minutes
Udy: weekday
dAy: date
0on: month
yEA: year

To exit: Press **SET + UP** keys for about 10 sec. or wait 60 sec.

How to export data and alarms to USB

1. Insert the **USB** key
2. Push the **DATA** key for more that 3 sec.
3. Controller starts uploading data to **USB**
4. At the end the following message will be displayed:
 - a. "End" if everything it's ok
 - b. "Err" if exporting has not taken place.

Alarms

The controller memorizes the last 100 alarms happened, together with their start and finish time. It's possible to export the alarms as described in the previous chapter.

Active alarm

Controller will show active alarm alternated with the temperature inside the unit.

Alarm signals

Message	Cause
"PF1"	Regulating probe TR3 failure
"HA1"	TR3 High Alarm
"LA1"	TR3 Low Alarm
"dA"	Door Open Alarm
"CA"	Serious Alarm

The alarm message is displayed until the alarm condition is recovered.

All the alarm messages are showed alternating with the temperature in the unit.

Except for the "PF1" which is flashing.

Defrosting, cleaning and maintenance

Defrosting:

The items stored in the freezer and the humidity of the surrounding air gradually cause frost and ice to form inside the freezer. A thin layer of frost or ice does not affect freezer performance, but the thicker the layer, the higher the energy consumption.

Never use electrical apparatus or sharp implements as these may damage the inside of the appliance.

Quick defrosting:

Small amounts of loose frost can be removed using a plastic scraper.

Defrosting has to be done regularly to prevent ice building.

The ice build depends on the use of the freezer. The more daily door openings – the more manual defrosting.

Door open/ close per 24h	Advised monthly manual defrosting
<5	1-2
<10	2-4
<15	4-6



It's important to clean the vacuum release valve free of ice as part of the manual defrosting process.

Thoroughly defrosting:

When the layer of frost and ice exceeds 4-5 mm the freezer should be completely defrosted. It is recommended that defrosting be performed when there are no items stored in the freezer.

Proceed as follows:

1. Disconnect the power supply.
2. Place a bowl of hot (but not boiling) water in the freezer, close the door and wait approx. 30 minutes before removing loose frost with the plastic scraper.
3. To prevent water from damaging the floor during defrosting, it is advisable to cover the floor around the freezer to protect against ice and splashes. When all the frost and ice have melted, clean the inside of the appliance using water with a mild, perfume-free detergent. Dry the freezer with a soft cloth.
4. Return items to the freezer when the required temperature has been reached.

Cleaning and maintenance

Before cleaning, disconnect the power supply and remove all loose fittings.

The appliance is best cleaned using warm water (max. 65°C) with a little mild, perfume-free detergent. Never use cleaning agents that scour. Use a soft cloth. Rinse with clean water and dry thoroughly. It is important to prevent water from entering the control panel.

The sealing strips around the door must be cleaned regularly to prevent discolouration



and prolong service life. Use clean water. After cleaning the sealing strip, check that it continues to provide a tight seal.

It is recommended that the wire and tubular condensers on the rear of the appliance be cleaned.

The condenser, the compressor and the compressor compartment must also be kept free of dust and dirt. Clean it with a vacuum cleaner regularly.

OBS: If the appliance is not to be used for any length of time, switch it off, disconnect the power supply, empty it, clean the inside and leave the door open to allow air circulation and prevent smells.

Fault finding

Fault	Possible cause	Remedy
Screen of keyboard is not lit.	Power failure; the fuse is blown; the appliance is not plugged in correctly, the power is cut.	Check that power is connected. Reset the fuse
Temperature in freezer too high	The ventilation grille is blocked. The door is not closed properly. The quantity of items placed in the freezer at a time is greater than the capacity of the appliance. Thick layer of frost and ice. The temperature setting is too high	Ensure unhindered air circulation Close the door and wait a few hours Wait a few hours Defrost the freezer. Lower the temperature setting.
Temperature in freezer too low.	The temperature setting is too low	Raise the temperature setting
Vibration or bothersome noise	The appliance is not level.	Level the appliance (For model with adjustable feet: use a spirit level)
Compressor runs continuously.	The temperature setting is too low. Too high room temperature.	Raise the temperature setting. Ensure adequate ventilation
Display or alarm log shows "RTC" error	The date and time is not set.	Please set the date and time

Warranty, spare parts and service

Warranty disclaimer

Faults and damage caused directly or indirectly by incorrect operation, misuse, insufficient maintenance, incorrect building, installation or mains connection. Fire, accident, lightning, voltage variation or other electrical interference, including defective fuses or faults in mains installations.

Repairs performed by others than approved service centres and any other faults and damage that the manufacturer can substantiate are caused by reasons other than manufacturing or material faults are not covered by the warranty.

Please note that changes to the construction of the appliance or changes to the component equipment of the appliance will invalidate warranty and product liability, and the appliance cannot be used lawfully. The approval stated on rating plate will also be invalidated.

Transport damage discovered by the buyer is primarily a matter to be settled between the buyer and the distributor, i.e. the distributor must ensure that such complaints are resolved to the buyer's satisfaction.

Before calling for technical assistance, please check whether you are able to rectify the fault yourself. If your request for assistance is unwarranted, e.g. if the appliance has failed as a result of a blown fuse or incorrect operation, you will be charged the costs incurred by your call for technical assistance.

Spare parts

When ordering spare parts, please state the type, serial and product numbers of your appliance. This information is given on the rating plate. The rating plate contains various technical information, including product-type and serial numbers.

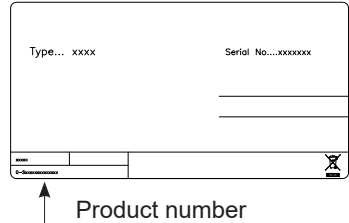

Disposal

Information for Users on Collection and Disposal of Old Equipment and used Batteries



These symbols on the products, packaging, and/or accompanying documents mean that used electrical and electronic products and batteries should not be mixed with general household waste. For proper treatment, recovery and recycling of old products and used batteries, please take them to applicable collection points, in accordance with your national legislation and the Directives 2002/96/EC and 2006/66/EC.

By disposing of these products and batteries correctly, you will help to save valuable resources and prevent any potential negative effects on human health and the environment which could otherwise arise from inappropriate waste handling.

For more information about collection and recycling of old products and batteries, please contact your local municipality, your waste disposal service or the point of sale where you purchased the items.

Penalties may be applicable for incorrect disposal of this waste, in accordance with national legislation.



For business users in the European Union.

If you wish to discard electrical and electronic equipment, please contact your dealer or supplier for further information.

Information on Disposal in other Countries outside the European Union

These symbols are only valid in the European Union. If you wish to discard this product, please contact your local authorities or dealer and ask for the correct method of disposal.

Note for the battery symbol:



This symbol might be used in combination with a chemical symbol. In this case it complies with the requirement set by the Directive for the chemical involved.



Supplied by STARLAB
www.starlabgroup.com

Reserving the right to alter specifications without prior notice.

Revision date: 21-11-2016
Drawing no.: 80.60.234 rev 04